



**Cambridge International Examinations**  
Cambridge International General Certificate of Secondary Education

CANDIDATE  
NAME

--

CENTRE  
NUMBER

--	--	--	--	--	--

CANDIDATE  
NUMBER

--	--	--	--



**MATHEMATICS**

Paper 4 (Extended)

**0580/41**

**October/November 2018**

**2 hours 30 minutes**

Candidates answer on the Question Paper.

Additional Materials:

Electronic calculator  
Tracing paper (optional)

Geometrical instruments

**READ THESE INSTRUCTIONS FIRST**

Write your Centre number, candidate number and name on all the work you hand in.

Write in dark blue or black pen.

You may use an HB pencil for any diagrams or graphs.

Do not use staples, paper clips, glue or correction fluid.

**DO NOT WRITE IN ANY BARCODES.**

Answer **all** questions.

If working is needed for any question it must be shown below that question.

Electronic calculators should be used.

If the degree of accuracy is not specified in the question, and if the answer is not exact, give the answer to three significant figures. Give answers in degrees to one decimal place.

For  $\pi$ , use either your calculator value or 3.142.

At the end of the examination, fasten all your work securely together.

The number of marks is given in brackets [ ] at the end of each question or part question.

The total of the marks for this paper is 130.

This document consists of **16** printed pages.

1 Marianne sells photos.

(a) The selling price of each photo is \$6.

(i) The selling price for each photo is made up of two parts, printing cost and profit.  
For each photo, the ratio printing cost : profit = 5 : 3.

Calculate the profit she makes on each photo.

\$ ..... [2]

(ii) Calculate her profit as a percentage of the selling price.

.....% [1]

(iii) Calculate the selling price of a photo in euros (€) when the exchange rate is €1 = \$1.091 .

€..... [2]

(b) Marianne sells two sizes of photo.  
These photos are mathematically similar rectangles.  
The smaller photo has length 15 cm and width 12 cm.  
The larger photo has area  $352.8 \text{ cm}^2$ .

Calculate the length of the larger photo.

..... cm [3]

(c) In a sale, Marianne buys a new camera for \$483.  
This is a reduction of 8% on the original price.

Calculate the original price of the camera.

\$ ..... [3]

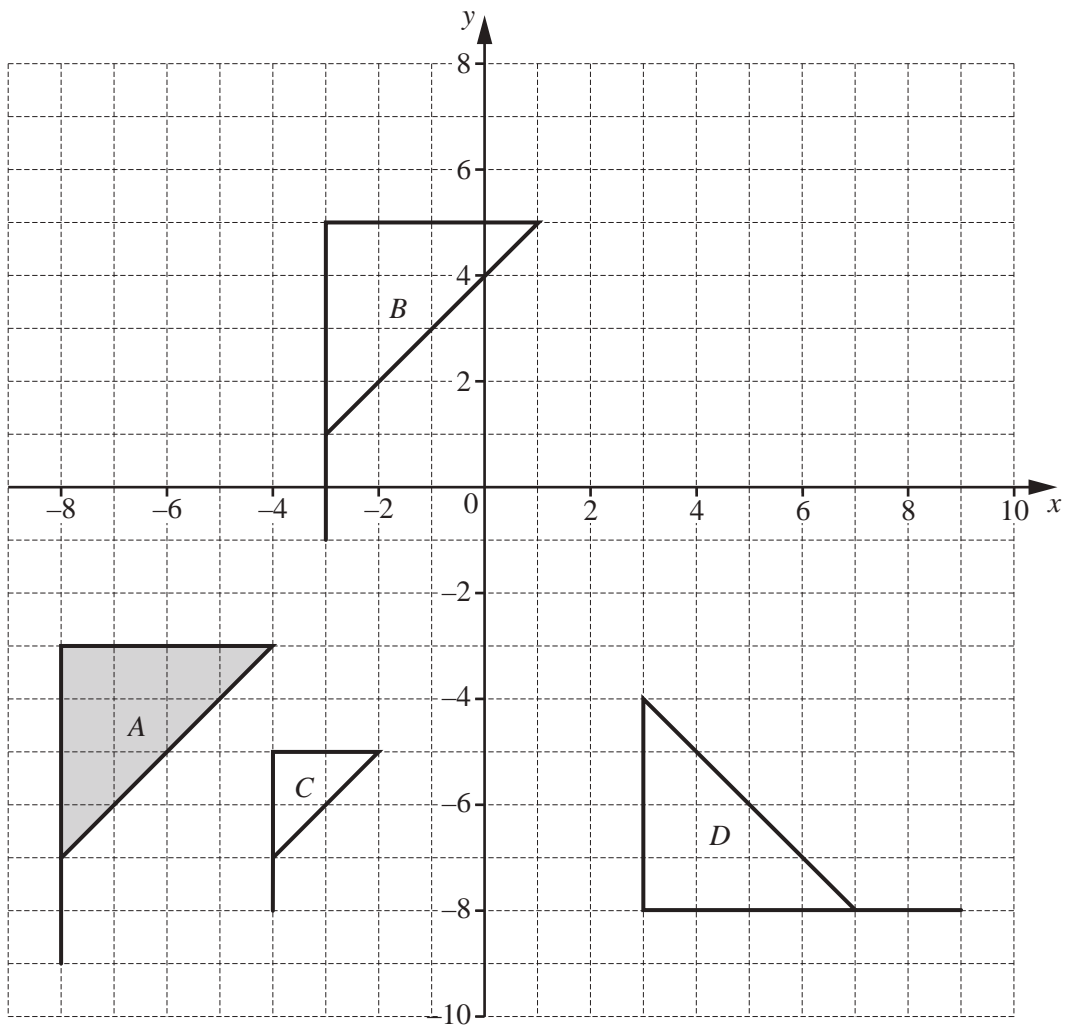

(a) Describe fully the **single** transformation that maps

(i) flag *A* onto flag *B*,

.....  
 ..... [2]

(ii) flag *A* onto flag *C*,

.....  
 ..... [3]

(iii) flag *A* onto flag *D*.

.....  
 ..... [3]

(b) Draw the reflection of flag *A* in the line  $y = -1$ . [2]

3 The table shows some values of  $y = x^3 - 3x^2 + x$ .

$x$	-0.75	-0.5	-0.25	0	0.5	1	1.5	2	2.5	2.75
$y$	-2.9	-1.4	-0.5		-0.1	-1	-1.9		-0.6	

(a) Complete the table. [3]

(b) On the grid, draw the graph of  $y = x^3 - 3x^2 + x$  for  $-0.75 \leq x \leq 2.75$ . [4]

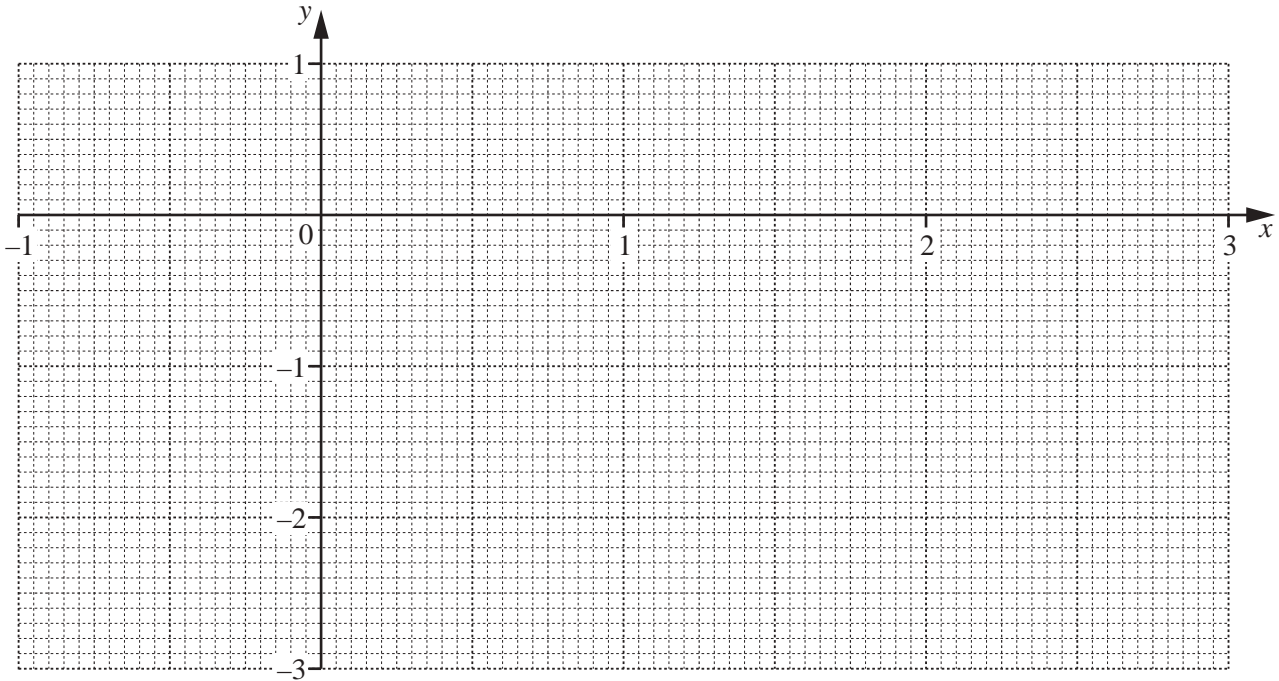

(c) Use your graph to complete the inequalities in  $x$  for which  $y > -1$ .

.....  $< x < .....$  and  $x > .....$

[3]

(d) The equation  $x^3 - 3x^2 + 2x - 1 = 0$  can be solved by drawing a straight line on the grid.

(i) Write down the equation of this line.

..... [2]

(ii) On the grid, draw this line and use it to solve the equation  $x^3 - 3x^2 + 2x - 1 = 0$ .

$x =$  ..... [3]

(e) By drawing a suitable tangent, find an estimate for the gradient of the graph of  $y = x^3 - 3x^2 + x$  at  $x = -0.25$ .

..... [3]

- 4 A school nurse records the height,  $h$  cm, of each of 180 children.  
The table shows the information.

Height ( $h$ cm)	$60 < h \leq 70$	$70 < h \leq 90$	$90 < h \leq 100$	$100 < h \leq 110$	$110 < h \leq 115$	$115 < h \leq 125$
Frequency	8	26	35	67	28	16

- (a) Calculate an estimate of the mean.  
Give your answer correct to 1 decimal place.

..... cm [4]

- (b) In a histogram showing the information, the height of the bar for the interval  $60 < h \leq 70$  is 0.4 cm.

Calculate the height of the bar for each of the following intervals.

$115 < h \leq 125$  ..... cm

$110 < h \leq 115$  ..... cm

$70 < h \leq 90$  ..... cm [3]

- (c) Complete the cumulative frequency table below.

Height ( $h$ cm)	$h \leq 70$	$h \leq 90$	$h \leq 100$	$h \leq 110$	$h \leq 115$	$h \leq 125$
Cumulative frequency						180

[2]

- (d) On the grid opposite, draw a cumulative frequency diagram.

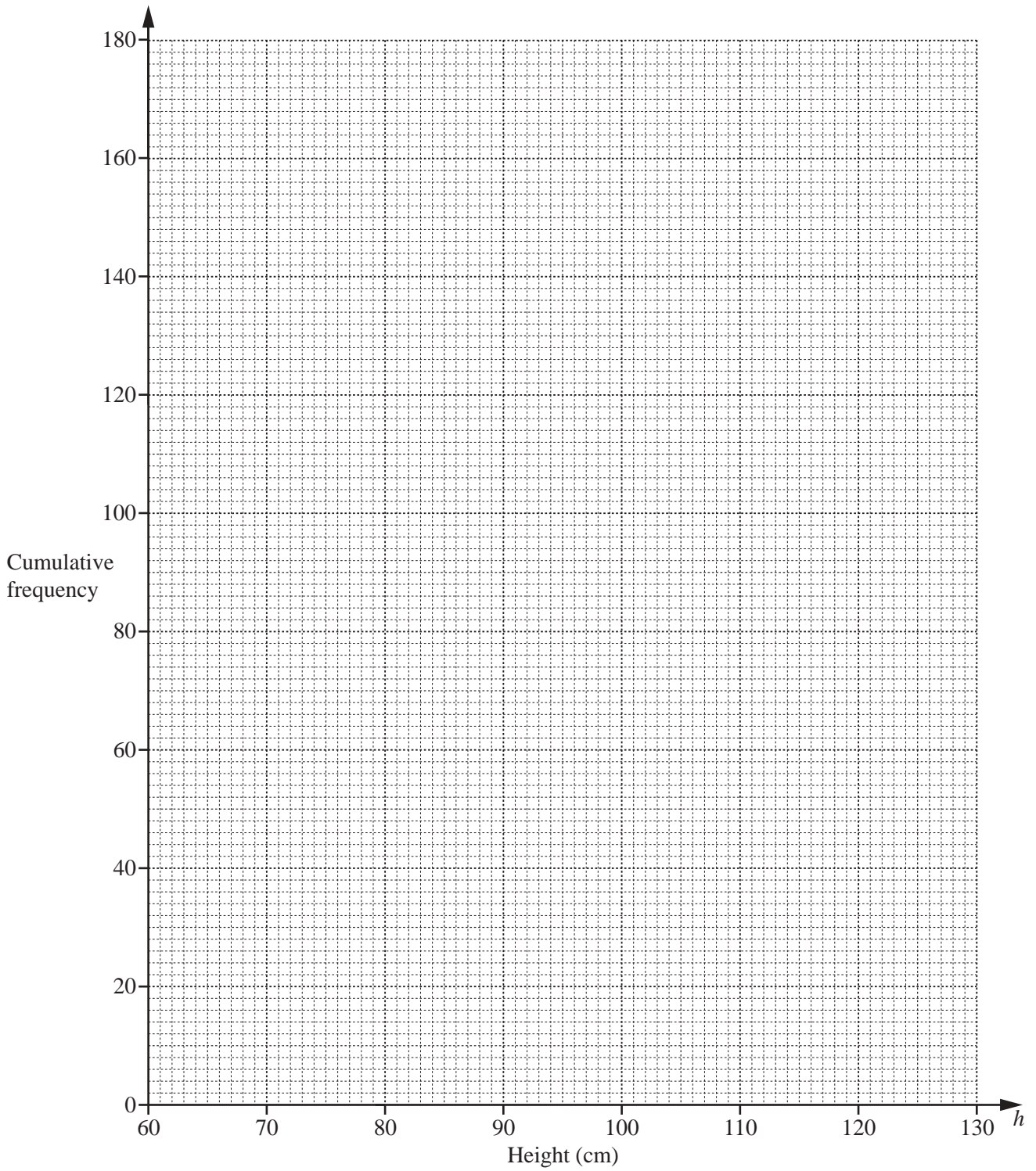

[3]

(e) Use your cumulative frequency diagram to find an estimate of

(i) the interquartile range,

..... cm [2]

(ii) the 70th percentile,

..... cm [2]

(iii) the number of children with height greater than 106 cm.

..... [2]

5

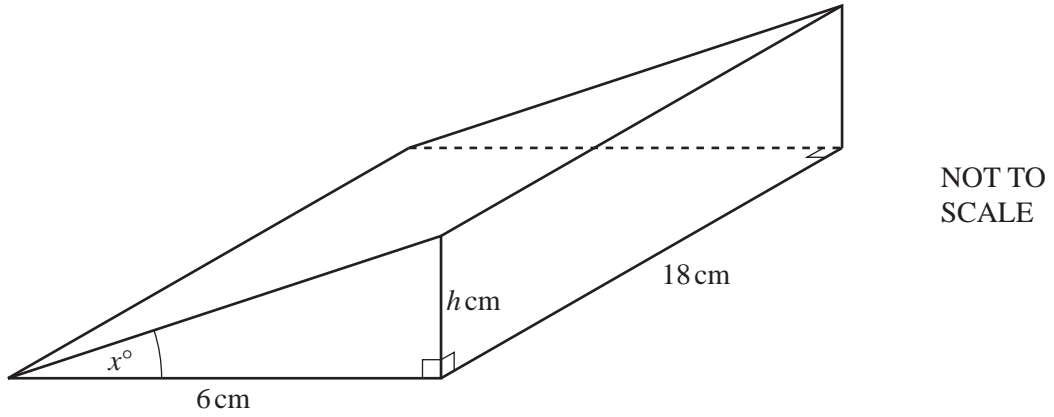

The diagram shows a prism with length 18 cm and volume  $253.8 \text{ cm}^3$ .  
 The cross-section of the prism is a right-angled triangle with base 6 cm and height  $h$  cm.

(a) (i) Show that the value of  $h$  is 4.7 .

[3]

(ii) Calculate the value of  $x$ .

$x = \dots\dots\dots$  [2]

(b) Calculate the total surface area of the prism.

$\dots\dots\dots \text{ cm}^2$  [6]



6 (a)

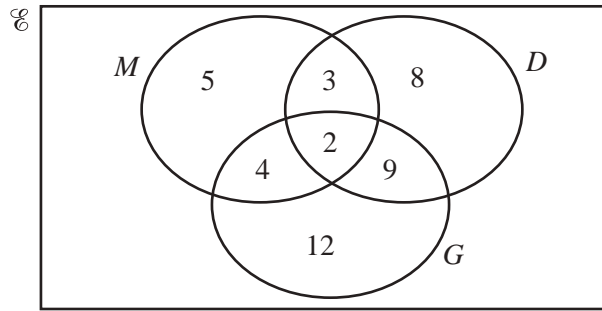

The Venn diagram above shows information about the number of students who study Music ( $M$ ), Drama ( $D$ ) and Geography ( $G$ ).

(i) How many students study Music? ..... [1]

(ii) How many students study exactly two subjects? ..... [1]

(iii) Two students are chosen at random from those who study Drama.  
 Calculate the probability that they both also study Music.  
 ..... [3]

(iv) In the Venn diagram above, shade  $M \cap D'$ . [1]

- (b) (i)  $\mathcal{E} = \{x : x \text{ is an integer and } 1 \leq x \leq 10\}$   
 $A = \{x : x \text{ is even}\}$   
 $4 \in A \cap B$   
 $n(A \cap B) = 1$   
 $(A \cup B)' = \{1, 7, 9\}$

Complete the Venn diagram below using this information.

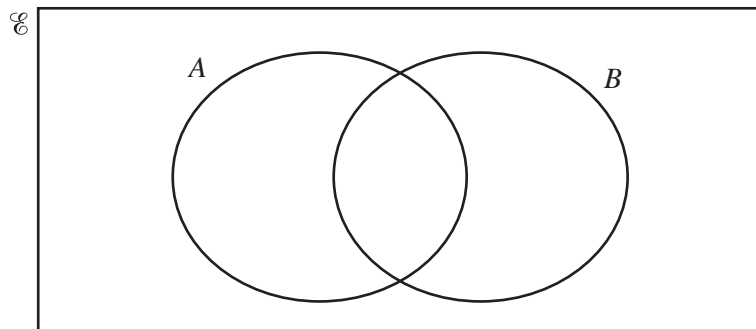

[4]

(ii) Use your Venn diagram to complete the statement.

$B = \{ \dots \}$  [1]

7 (a)

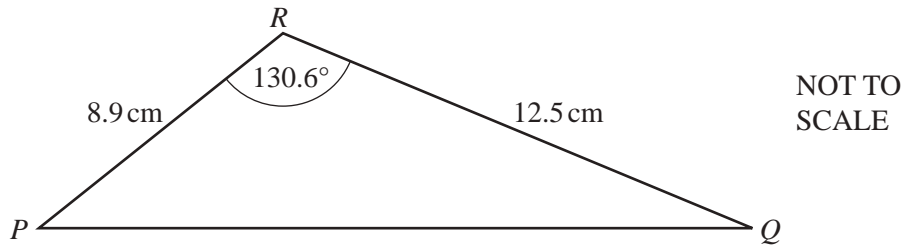

Calculate the area of triangle  $PQR$ .

.....  $\text{cm}^2$  [2]

(b)

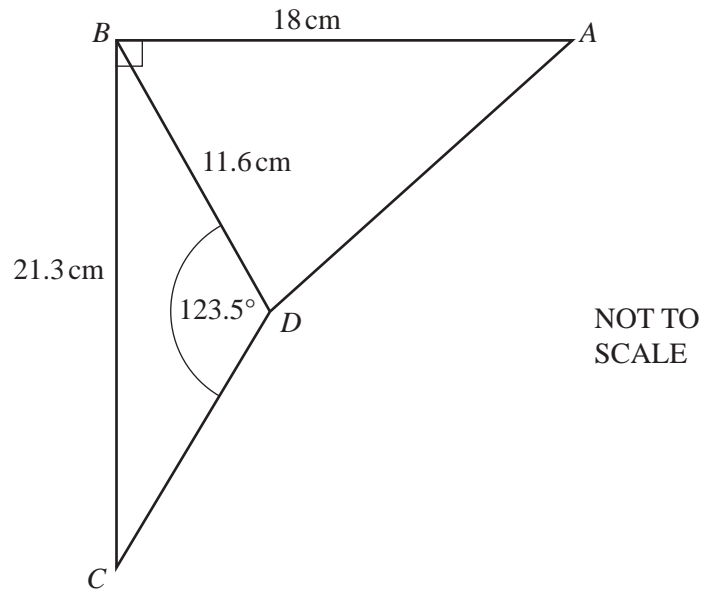

In the diagram,  $AB = 18\text{ cm}$ ,  $BC = 21.3\text{ cm}$  and  $BD = 11.6\text{ cm}$ .  
 Angle  $BDC = 123.5^\circ$  and angle  $ABC$  is a right angle.

(i) Calculate angle  $BCD$ .

Angle  $BCD = \dots\dots\dots$  [3]

(ii) Calculate  $AD$ .

$AD = \dots\dots\dots$  cm [5]

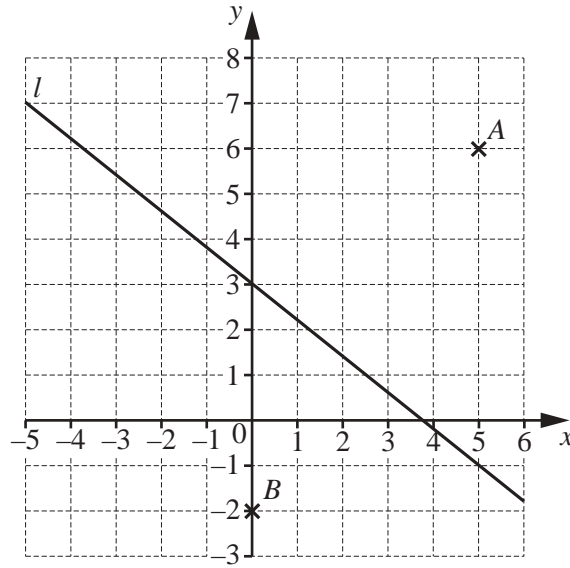

(a) Write down the co-ordinates of A. (..... , .....) [1]

(b) Find the equation of line  $l$  in the form  $y = mx + c$ .  
 $y = \dots\dots\dots$  [3]

(c) Write down the equation of the line parallel to line  $l$  that passes through the point B.  
 $\dots\dots\dots$  [2]

(d)  $C$  is the point (8, 14).  
 (i) Write down the equation of the line perpendicular to line  $l$  that passes through the point  $C$ .  
 $\dots\dots\dots$  [3]

(ii) Calculate the length of  $AC$ .  
 $\dots\dots\dots$  [3]

(iii) Find the co-ordinates of the mid-point of  $BC$ .  
 (..... , .....) [2]

- 9 Paulo and Jim each buy sacks of rice but from different shops.  
Paulo pays \$72 for sacks costing \$ $m$  each.  
Jim pays \$72 for sacks costing \$ $(m + 0.9)$  each.

(a) (i) Find an expression, in terms of  $m$ , for the number of sacks Paulo buys.

..... [1]

(ii) Find an expression, in terms of  $m$ , for the number of sacks Jim buys.

..... [1]

(b) Paulo buys 4 more sacks than Jim.

Write down an equation, in terms of  $m$ , and show that it simplifies to  $10m^2 + 9m - 162 = 0$ .

[4]

(c) (i) Solve  $10m^2 + 9m - 162 = 0$ .

$m = \dots\dots\dots$  or  $m = \dots\dots\dots$  [3]

(ii) Find the number of sacks of rice that Paulo buys.

..... [1]

10

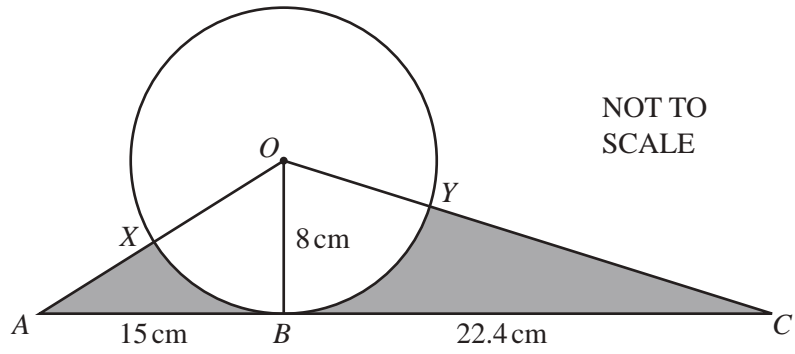

The diagram shows a circle, centre  $O$ .  
 The straight line  $ABC$  is a tangent to the circle at  $B$ .  
 $OB = 8$  cm,  $AB = 15$  cm and  $BC = 22.4$  cm.  
 $AO$  crosses the circle at  $X$  and  $OC$  crosses the circle at  $Y$ .

(a) Calculate angle  $XOY$ .

Angle  $XOY = \dots\dots\dots$  [5]

(b) Calculate the length of the arc  $XY$ .

$\dots\dots\dots$  cm [2]

(c) Calculate the total area of the two shaded regions.

..... cm<sup>2</sup> [4]

**Question 11 is printed on the next page.**

11 (a) Factorise  $5m^2 - 20p^4$ .

..... [3]

(b) Make  $P$  the subject of the formula  $A = P + \frac{PRT}{100}$ .

$P =$  ..... [3]

---

Permission to reproduce items where third-party owned material protected by copyright is included has been sought and cleared where possible. Every reasonable effort has been made by the publisher (UCLES) to trace copyright holders, but if any items requiring clearance have unwittingly been included, the publisher will be pleased to make amends at the earliest possible opportunity.

To avoid the issue of disclosure of answer-related information to candidates, all copyright acknowledgements are reproduced online in the Cambridge International Examinations Copyright Acknowledgements Booklet. This is produced for each series of examinations and is freely available to download at [www.cie.org.uk](http://www.cie.org.uk) after the live examination series.

Cambridge International Examinations is part of the Cambridge Assessment Group. Cambridge Assessment is the brand name of University of Cambridge Local Examinations Syndicate (UCLES), which is itself a department of the University of Cambridge.